

# MYLOCOSOUND

## Installation and Trouble Shooting Manual

## European Edition

- Easy installation using screw terminals with no soldering.
- Uses a TV remote control to adjust the sounds to match the prototype loco.
- For track powered DC or DCC or battery powered, radio controlled or ride on locomotives.
- Measures 55mm x 33mm x 11mm.

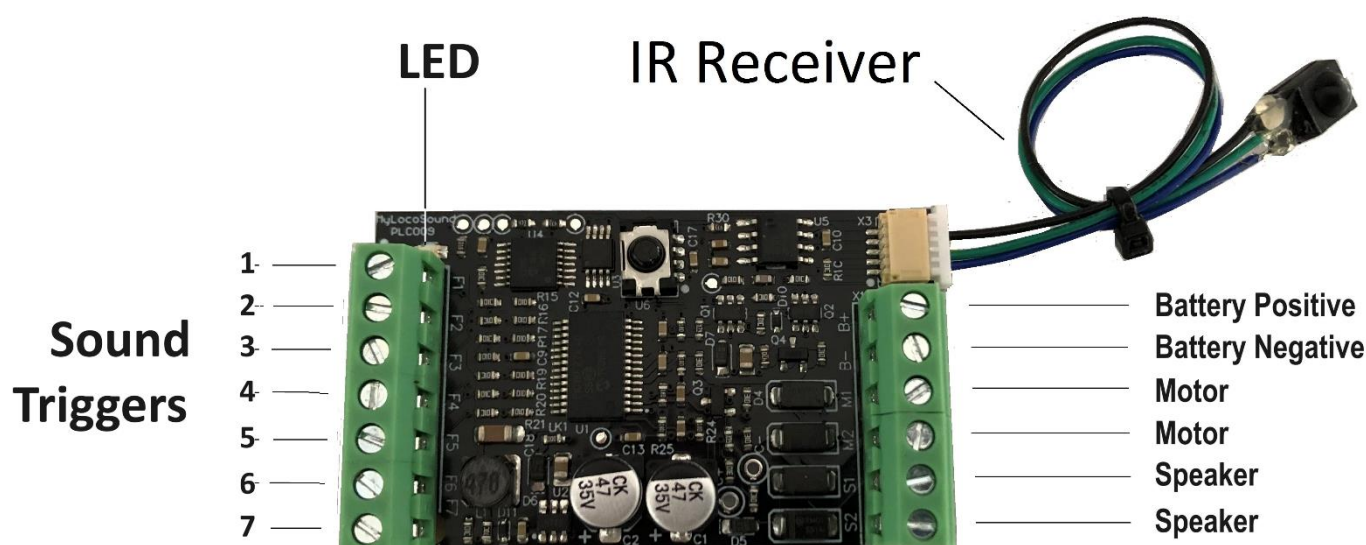

## 1. CONTENTS

	Page
1. Contents	1
2. Overview	2
3. Speakers and Sound quality	2
4. Installing in analogue DC track powered vehicles	3
5. Installing in DCC track powered vehicles	4
6. Installing in battery powered vehicles	5
7. Installing in ride on vehicles	6
8. Infra-red receivers	7
9. The TV remote control	7
10. Trouble shooting	8

## 2. OVERVIEW

The soundcard generates recorded sounds from actual locomotives, trams and railcars. The terminal connections on the right in the photo above are necessary for the soundcard to generate sounds which vary with the loco speed and load. The terminal connections on the left trigger the various sounds where the locomotive controller has the appropriate outputs available. The trigger terminals are labelled F1 to F7 and are referred to by these labels in these instructions. For example, "Triggering F1" means to close a contact between the F1 terminal and the Battery negative terminal.

Sounds can also be triggered by a Sony infra-red TV remote control which can be purchased locally. Low cost, universal, TV remote controls are available from most consumer electronics stores and need to be set to Sony coding to work with the soundcard. Although it can be used when running in the garden, the remote control is intended mainly for the adjustment and testing of sounds.

The remote control communicates with the soundcard via two infra-red receivers. One is located on the soundcard and the other is on a flying lead which allows it to be fixed to any external surface of the loco. Adjustments to the sounds can then be made without taking the loco apart to access the soundcard.

### 3. SPEAKERS AND SOUND QUALITY

The soundcard requires an 8 ohm loudspeaker which is not included. A 4 ohm speaker can also be used but you may cause the soundcard to overheat and temporarily shut down if the volume is very high and the soundcard is in a confined space. Your choice of speaker is highly important because it determines the quality of the sound produced.



1. To get maximum volume, the rated (or RMS) power should be 3 watts. A 1 watt or lower speaker will fall short on volume. Speakers exceeding 3 watts can be used but will not produce any more volume due to the limited output of the soundcard amplifier.
2. The resonant frequency should ideally be below 350 Hz but certainly below 500 Hz. The lower the resonant frequency, the deeper and more realistic the sounds.
3. Use the largest diameter which you can fit in your loco. Two inches is the most popular.



For a better quality sound and more volume, the speaker needs to be baffled. That means that it needs to be built into the front face of an airtight box so that sound is heard only from the front of the speaker and

none from the back. The plastic top of a spray paint can is good for making a baffle as shown in the diagram.

A good solution, which ensures high quality sound with lots of deep throbbing bass, is to purchase an 8 ohm impedance external speaker unit for iPod and MP3 music players and remove the two speaker modules, in their enclosures, for use in two locos. These are readily available at consumer electronics stores.



Speakers can be connected to the terminals either way around.

## Important Notes

The soundcard is designed for outdoor use and may not work correctly under bright incandescent lights on a workbench. LED lights are okay.

The soundcard is in a "sleep" mode when not in use. Connecting it to power at the B+ and B- terminals will not wake it up. It must also be connected to a motor at the M1 and M2 terminals as well. The small voltage it sees at the motor will wake it up and it will then stay awake for as long as it has power.

#### 4. INSTALLING THE SOUNDCARD IN ANALOGUE DC TRACK POWERED VEHICLES

The soundcard is suitable for use on analogue DC track powered railways on which the following wiring diagram should be used:

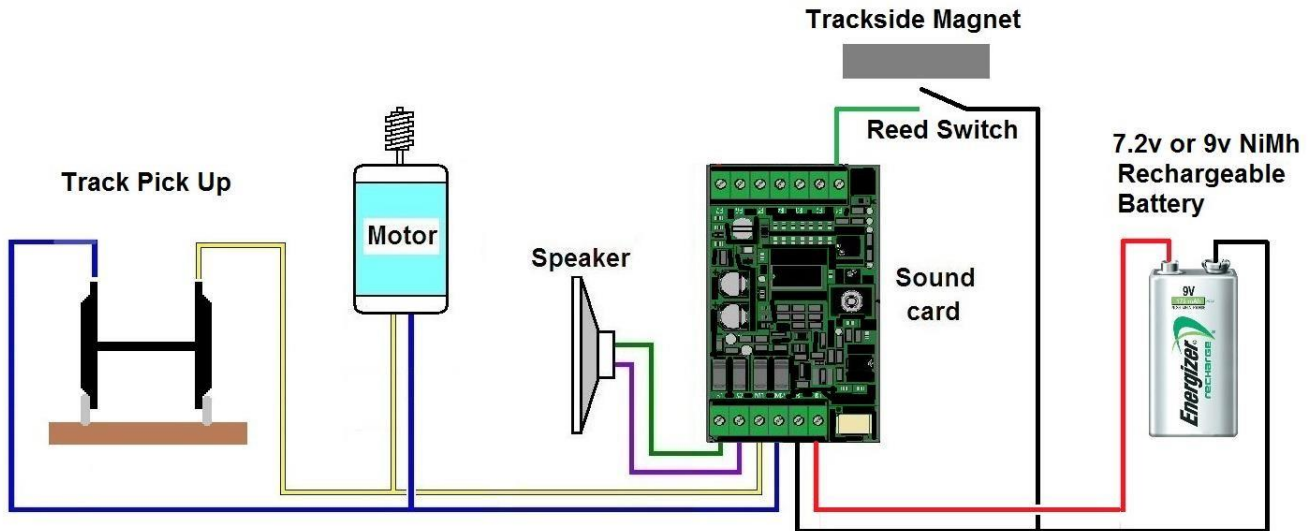

The wiring diagram below shows the connections for the DC jumper board in a Bachmann locomotive.

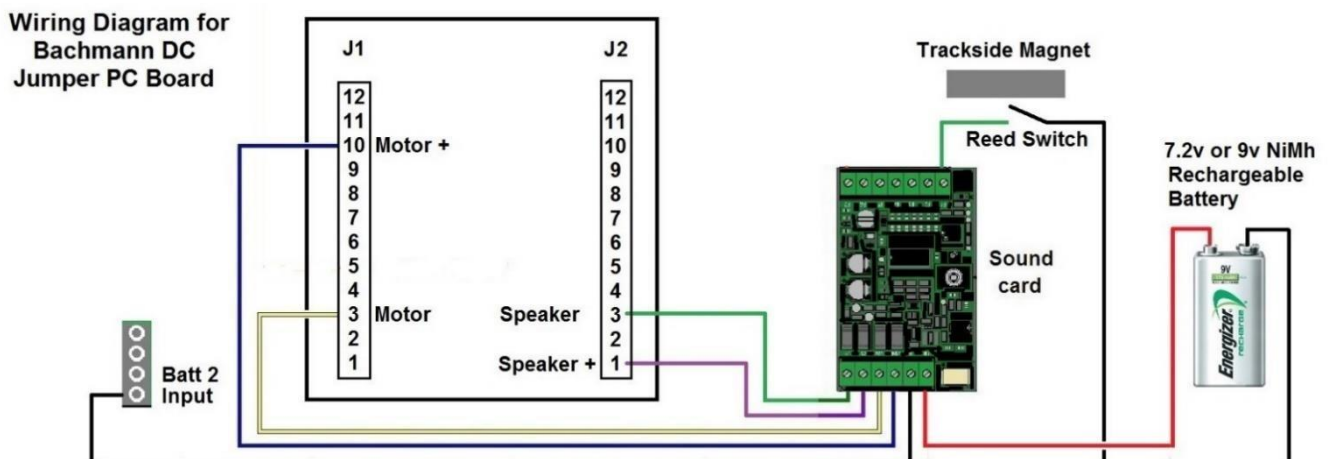

When the motor voltage is below seven volts it is insufficient to power the soundcard. Therefore, a 9v volt PP3 or a 7.2v cordless phone battery is used to drive the soundcard and produce sound when the loco is static or moving slowly. This battery will be automatically recharged whenever the motor voltage is at about 1.8 volts higher than the battery voltage so there is often never a need to remove the battery for recharging. However, the battery must be a Nickel Metal Hydride type; Lithium and Nickel Cadmium batteries must not be used.

If your loco has a motor on/off switch, it can be used to recharge the battery while the loco is stopped. Just switch off the motor and turn up the track voltage to at least 11VDC.

Another option is to fit a recharging socket so that the support battery can be recharged, using an external battery charger, without removing the battery from the loco. We recommend using a three pin, panel mounted DC power socket which, when wired as shown, isolates the soundcard when the charger is plugged in.

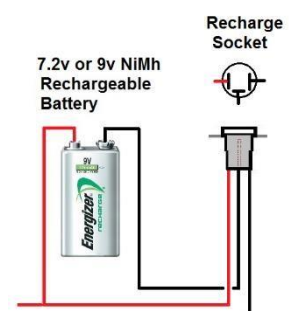

On analogue DC layouts which have pure DC controllers (as opposed to PWM controllers) you may need to give the throttle a bit of a tweak to start the sound. On those layouts, the sound will automatically turn off after one minute of inactivity and another tweak will turn it back on. With the more common PWM controllers and with DCC the sound will turn on automatically and stay on.

When the loco is removed from the track the soundcard will go into a “sleep” mode to preserve the battery charge. A fully charged battery should retain charge for over a year.

Because most DC controllers do not have function buttons, an alternative way of triggering the horn, whistle, bell and other sounds needs to be found. The options are:

1. You can set the horn or whistle to sound automatically three times a minute when the train is running. Other sounds can also be triggered automatically. This is described in the operating manual.
2. You can connect the soundcard horn trigger to a reed switch which you mount on the bottom of the loco. Then install magnets in the track where you want the horn to sound eg. at the approaches to a level crossing. The horn will then sound briefly as the loco crosses each magnet.
3. Use the TV remote control to trigger all the sounds as described in the operating manual. However, infra-red remote controls are not designed for long distance use outside. On an overcast but bright day, the remote control, powered by AA or AAA batteries will probably operate up to three metres away.

Any combination, or all, of these methods can be used.

## 5. INSTALLING THE SOUND CARD IN DCC TRACK POWERED VEHICLES

On DCC track powered railways in locomotives using a basic, motion only decoder, the wiring is a little different:

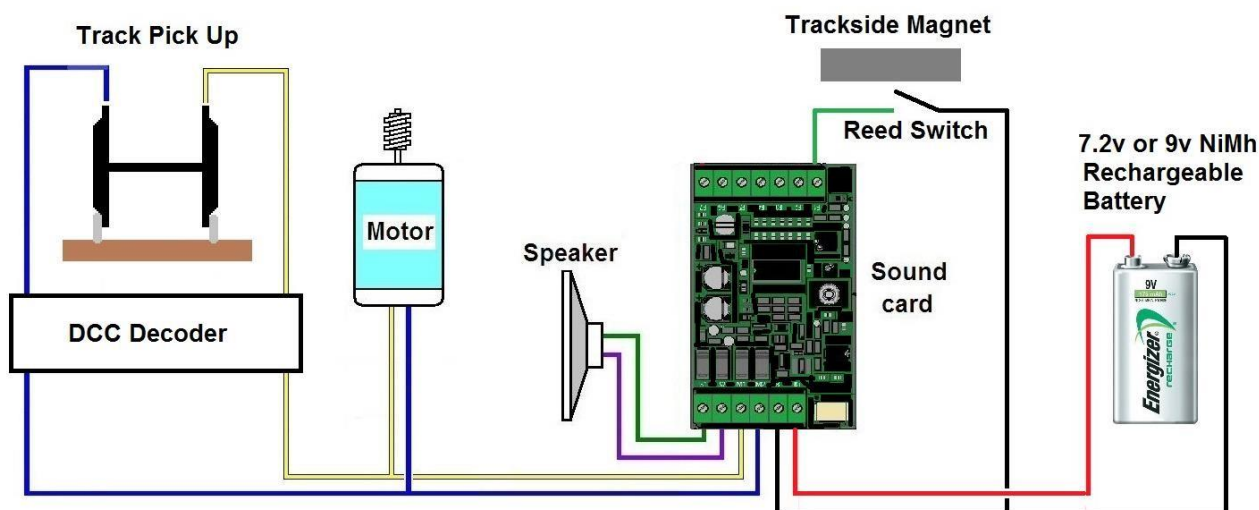

Some decoders have a constant DC power output which can replace the battery if it is in the voltage range 8 to 24 volts.

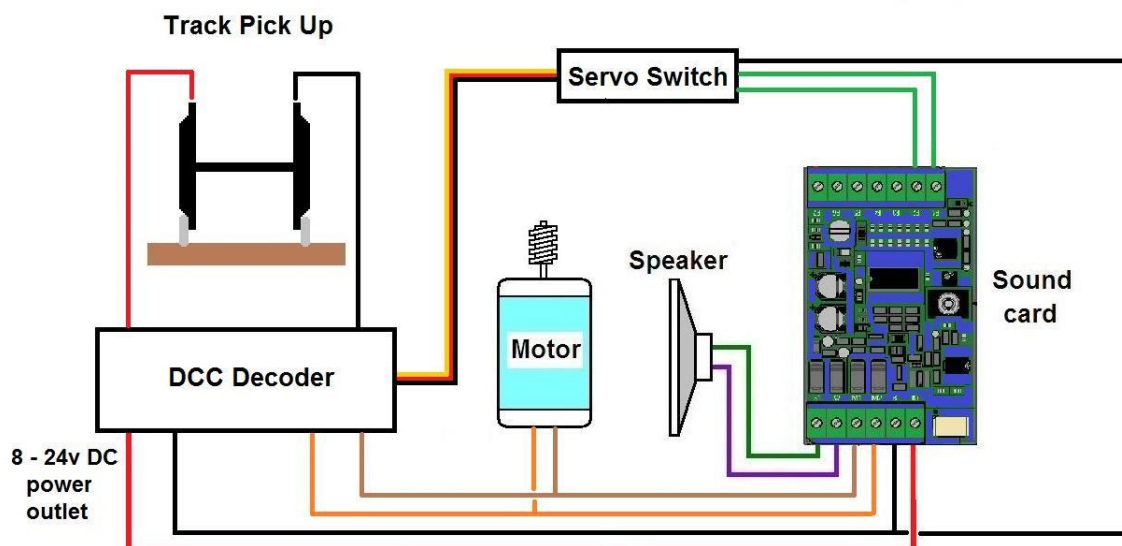

The soundcard is not a DCC decoder and cannot trigger sounds directly from the controller. Some decoders have a servo output which can be used to trigger sounds from the controller buttons by using a servo switch. These connection options are shown below:

Many decoders also have function outputs which can be used to trigger sounds. However, this is technically difficult and you should only attempt it if you are very familiar with your decoder and the setting of CVs. You can also trigger sounds by:

1. Setting the horn or whistle to sound automatically three times a minute when the train is running. Other sounds can also be triggered automatically. This is described in the operating manual.
2. You can connect the soundcard horn trigger to a reed switch which you mount on the bottom of the loco. Then install magnets in the track where you want the horn to sound e.g. at the approaches to a level crossing. The horn will then sound briefly as the loco crosses each magnet.
3. Use the TV remote control to trigger all the sounds as described in the operating manual. However, infra-red remote controls are not designed for long distance use outside. On an overcast but bright day, the remote control, powered by AA or AAA batteries will probably operate up to three metres away.

## 6. INSTALLING THE SOUND CARD IN BATTERY POWERED VEHICLES

The wiring diagram shows a typical installation for a battery powered radio control system.

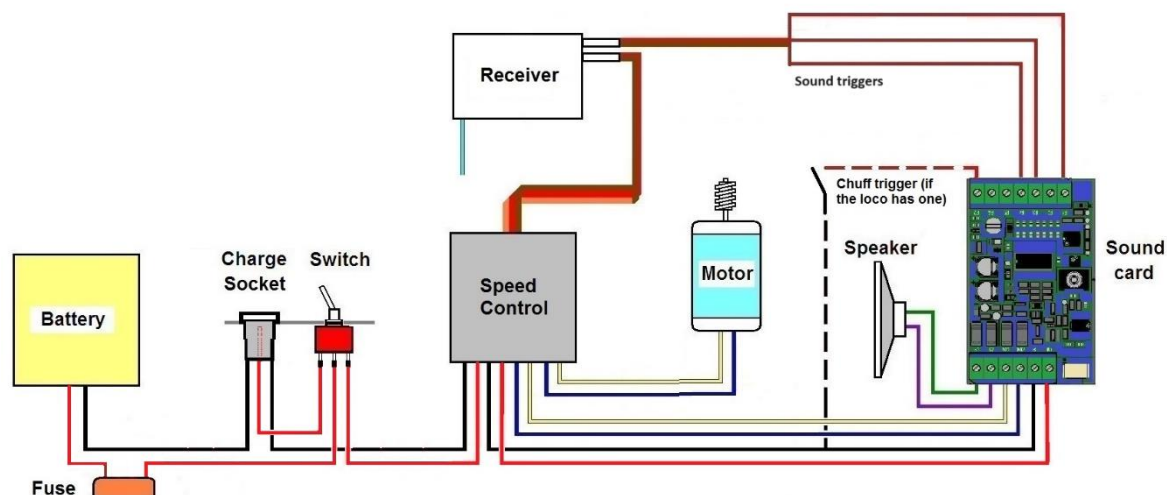

Wiring diagrams for many radio control systems can be found in the INSTALLATIONS menu at [www.mylocosound.com](http://www.mylocosound.com).



## 7. INSTALLING IN RIDE ON LOCOMOTIVES

When used in 5 inch and 7¼ inch ride on railways there is a lot of environmental noise. The output of the soundcard alone is not sufficient for these environments and an external amplifier needs to be used. The wiring diagram on the next page shows how the soundcard can be interfaced to a commercial stereo amplifier in a loco with 24v motors powered by two 12 V batteries.

Note that the soundcard can handle a maximum of 24 volts DC. A battery which is labelled as 24 volts will typically output 28 volts when fully charged and will therefore damage the soundcard if connected directly. The two 10K resistors on the M1/M2 terminals keep the voltage down to 24v.

A 2x15 watt stereo amplifier is suitable. Other amplifiers may require the 100Ω resistor to be changed. If the output volume is too low then raise the value of the 100Ω resistor.

A single speaker can be used on the right output or two speakers on the left and right outputs.

Any of the sound functions can be used by means of a pushbutton between the function terminal and ground. Only sound function 1,

the horn or whistle, wiring is shown in the diagram. The installation can be made more robust by enclosing the soundcard, capacitor and two resistors into a plastic project box as shown in the diagram.

The whole can then be fixed to the top of the amplifier using silicon. Select a speaker which matches the impedance and power output of the amplifier. It is also important to make a soundbox which is an airtight fit to the back of the speaker. This will improve both volume and sound quality.

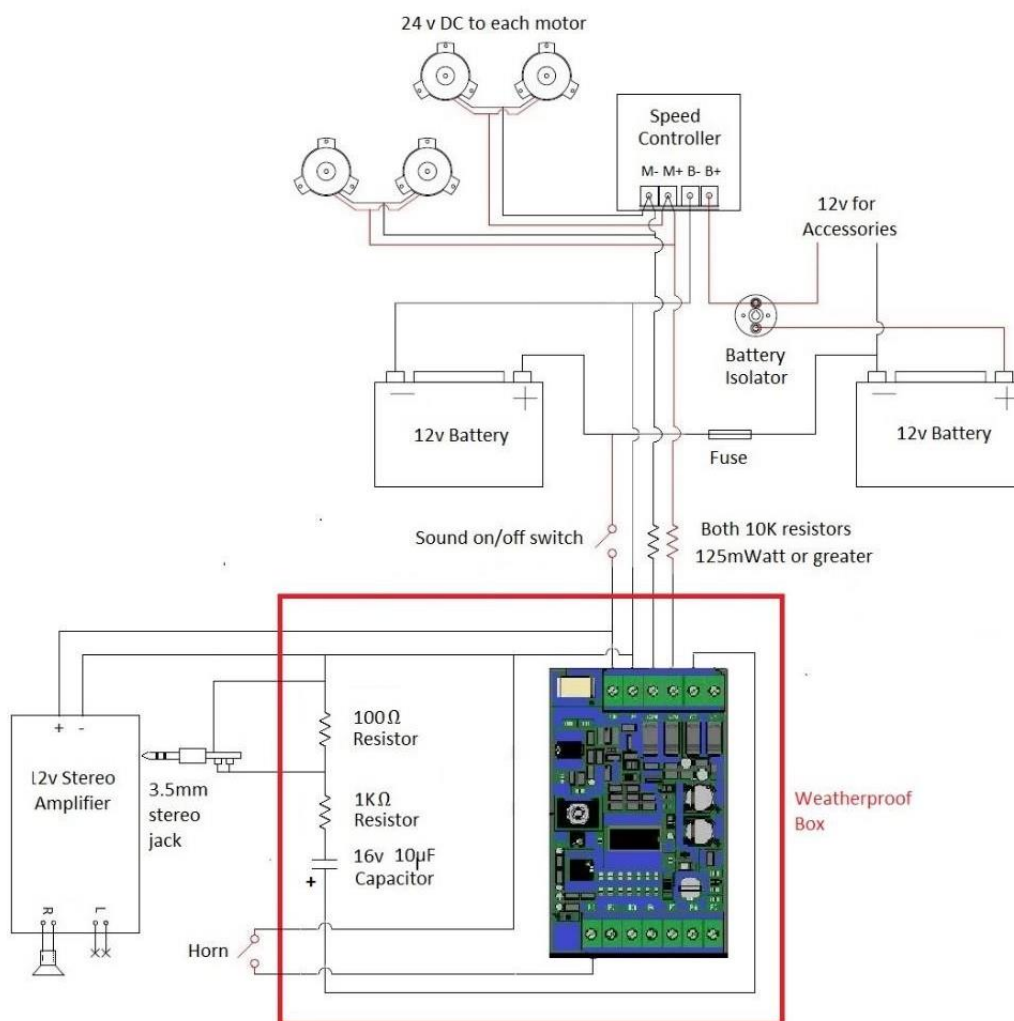

## 8. THE INFRA-RED RECEIVERS

The infra-red receivers accept commands from the handheld remote control to adjust or trigger sounds. Two receivers are provided. One is fixed in the middle of the soundcard. The other is on a flying lead which plugs into the small white socket as shown on page one.

In some installations, the soundcard is visible when installed in the loco. This usually occurs when the soundcard is mounted on the floor of a cab, with or without windows. In this case, the remote control can be pointed directly at the soundcard and the on-board receiver is all that is needed.

If the soundcard is within the loco and is not visible then the flying lead needs to be used. Plug it into the white socket and glue the black receiver, round side outwards, to any external surface of the loco to which you can easily point the TV remote. Do not paint the receiver. When the soundcard is on the floor of the vehicle then a common practice is to drill a hole in the floor and glue the black receiver to the underside. You can then operate the TV remote by pointing it under the vehicle so that the IR signal bounces up off the sleepers and ballast.



## 9. THE TV REMOTE CONTROL

The soundcard will operate with any Sony™ TV remote control using the buttons described in this section. It will also operate with any universal remote control when it is set to Sony coding. You will probably find a number of codes listed for Sony and will need to try each one until

you get to the code which operates the soundcard volume, mute and function buttons correctly.

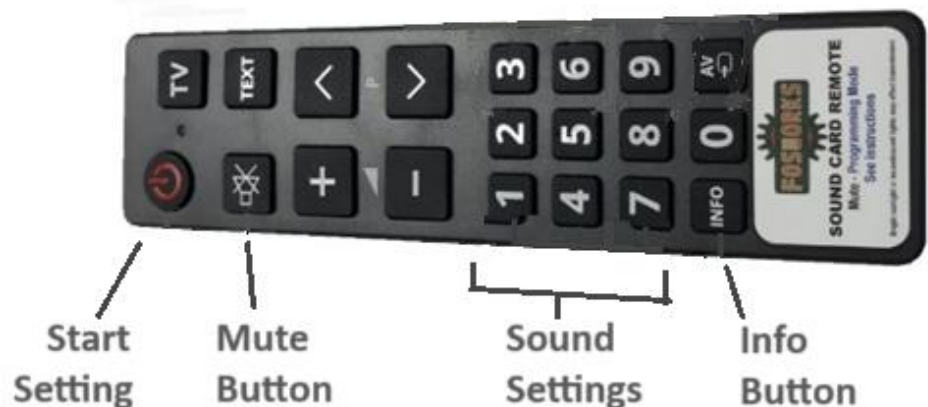

Please ensure that your remote control has batteries installed and follow the instructions which come with it to set the coding. The remote control shown here is the Fosworks TV remote. Hold down the POWER and MUTE buttons together until the red light stays on. Press and release the 0, then the 1, then the 4 and then the 0 button in turn. The red light will then flash three times and the remote control is then ready for use.

Note that the buttons on the remote control auto-repeat if held down. If you want a single event to occur, like turning on the safety valve, then press the safety valve and release it immediately. If you want to make a large change in volume or tone then you can hold the button down to avoid the need to press the button repeatedly.

The **Mute** button will start and stop the sound and lets you select the different sounds. The **MENU** button changes the way the sounds operate.

## 10. TROUBLE SHOOTING GUIDE

### THE TV REMOTE CONTROL WON'T WORK

Start the soundcard, press any button on the remote control and the LED should flash. If it does not flash then the battery probably needs replacing. If the LED flashes but the soundcard does not respond then the Sony™ coding may have been lost and can be reset as follows.

If the TV remote still does not work then the Sony™ coding may have been lost and will need to be re-entered. For the Fosworks TV remote, hold down the POWER and MUTE buttons together until the red light stays on. Press and release the 0, then the 1, then the 4 and then the 0 button in turn. The red light will then flash three times and the remote control is then ready for use.

If the remote control still does nothing then the problem may be the infra-red receiver on the loco which must not be painted or obstructed.

### I GET NO SOUND AT LOW SPEEDS WHEN USING TRACKPOWER

On trackpower, you may get no sound at low speeds until the track voltage gets up to about nine volts. This indicates that the support battery is flat. Charge the battery by running the loco for ten minutes with the track voltage at least one volt more than the nominal battery voltage.

### I GET NO SOUND AT ALL

Press the Mute button on the remote control in case the sound has been accidentally turned off.

Switch the loco off and then on again. When the soundcard starts, the LED should flash once. If not then use a multimeter to check that there is at least nine volts at the B+ and B- terminals and the M1/M2 voltage is greater than zero to wake up the soundcard. If not then check your wiring in case something has come adrift.

Check that the speaker is connected correctly.

If you are bench testing and there is a light shining on circuit board then this can put the soundcard into factory programming mode and stop the sound. In that case, the yellow LED next to the F1 terminal will stay on. You can fix this by covering the IR receiver on the soundcard and on the flying lead, if fitted.

### THE SOUND CARD MAKES A CLICKING NOISE OR SHUTS DOWN

This most often occurs when the horn is sounded. It is caused by the soundcard restarting because there is insufficient voltage in the track or the battery to sustain the volume setting. Recharge the battery.

### WHEN INSTALLED IN A LOCO, THE SOUND STOPS INTERMITTENTLY AND I HAVE TO RESET THE CONTROLLER TO GET IT GOING AGAIN

The soundcard maximum output is 2 amps. If this is exceeded as a result of a short circuit, a heavy load and/or high volume settings then the soundcard will shut down. Also, if the soundcard is installed in a very confined space and is run for a prolonged period at high power then it can overheat and switch itself off while it cools down.



---

## HOW TO RESET YOUR SOUNDCARD

A time may come when you have been adjusting the sound and you want to start again. This can be achieved by resetting the soundcard back to the settings when it left the factory. You can do this by pressing the 0 button on the remote control and hold it down for three seconds. The soundcard will beep five times when the reset is complete.

Installation Instructions - Fosworks. 30 June 2024

For more information and other installation wiring diagrams, please visit the web site at [www.mylocosound.com](http://www.mylocosound.com) or e-mail [sales@mylocosound.com](mailto:sales@mylocosound.com).

Copyright © 2013-24 MyLocoSound Pty. Ltd.